

## MIT Open Access Articles

*Autonomous Personal Mobility Scooter for  
Multi-Class Mobility-On-Demand Service*

The MIT Faculty has made this article openly available. **Please share** how this access benefits you. Your story matters.

**Citation:** Andersen, Hans, You Hong Eng, Wei Kang Leong, Chen Zhang, Hai Xun Kong, Scott Pendleton, Marcelo H. Ang Jr., and Daniela Rus. "Autonomous Personal Mobility Scooter for Multi-Class Mobility-On-Demand Service." In 2016 IEEE 19th International Conference on Intelligent Transportation Systems (ITSC 2016), Convention Center, Windsor Oceanico Hotel, Rio de Janeiro, Brazil, November 1-4, 2016.

**As Published:** [https://its.papercept.net/conferences/conferences/ITSC16/program/ITSC16\\_ContentListWeb\\_1.html#tud-t1](https://its.papercept.net/conferences/conferences/ITSC16/program/ITSC16_ContentListWeb_1.html#tud-t1)

**Publisher:** Institute of Electrical and Electronics Engineers (IEEE)

**Persistent URL:** <http://hdl.handle.net/1721.1/105326>

**Version:** Author's final manuscript: final author's manuscript post peer review, without publisher's formatting or copy editing

**Terms of use:** Creative Commons Attribution-Noncommercial-Share Alike



# Autonomous Personal Mobility Scooter for Multi-Class Mobility-on-Demand Service

Hans Andersen<sup>1</sup>, You Hong Eng<sup>2</sup>, Wei Kang Leong<sup>2</sup>, Chen Zhang<sup>2</sup>, Hai Xun Kong<sup>2</sup>,  
Scott Pendleton<sup>1</sup>, Marcelo H. Ang Jr.<sup>1</sup>, and Daniela Rus<sup>3</sup>

**Abstract**—In this paper, we describe the design and development of an autonomous personal mobility scooter that was used in public trials during the 2016 MIT Open House, for the purpose of raising public awareness and interest about autonomous vehicles. The scooter is intended to work cooperatively with other classes of autonomous vehicles such as road cars and golf cars to improve the efficacy of Mobility-on-Demand transportation solutions. The scooter is designed to be robust, reliable, and safe, while operating under prolonged durations. The flexibility in fleet expansion is shown by replicating the system architecture and sensor package that has been previously implemented in the road car and golf cars. We show that the vehicle performed robustly with small localization variance. A survey of the users shows that the public is very receptive to the concept of the autonomous personal mobility device.

## I. INTRODUCTION

Mobility-on-Demand (MoD) services, such as car sharing or on demand taxi services, have seen huge growth in the last few years through service providers like Uber and Lyft. Autonomous vehicles have long been awaited to usher in the next generation of mobility, especially in highly urbanized areas such as Singapore. A truly “on-demand” mobility service can be better realized by utilizing a fleet of autonomous vehicles throughout a city.

Autonomous vehicles offer potential for additional safety, increased productivity, greater accessibility, better road efficiency, and reduced environmental impact. Added potential benefits include higher throughput, better vehicle utilization, reduced number of vehicles on the road, in line with Singapore’s drive towards car-lite society [1], less congestion and travel time, and lower cost.

While most current MoD systems are limited in the range of vehicle classes available to customers, autonomous vehicles can come in different classes such as buses, road cars, personal transport vehicle, etc. Furthermore, depending on usage cases, aquatic and aerial transportation modes can also be combined with ground transportation modes in a meaningful way to fully realize point-to-point transportation of a passenger. Each of these vehicle classes has strengths

and weaknesses that offer advantages in certain environments.

A truly door-to-door MoD service requires a multi-class fleet of autonomous vehicles, where each class of vehicle would be chosen based on intended environment, ideally all managed by a common service provider. By cooperatively allowing interchanges within such a multi-class autonomous vehicle fleet, a wider variety of environments could be serviced, yielding better area coverage and offering more flexible, convenient transportation options to the customer.

In our previous work [2], we discussed the utility of having a multi-class autonomous vehicle fleet for a MoD system, through a simple usage case involving a road car (Mitsubishi iMIEV) and golf cars on the National University of Singapore campus. Both classes of vehicles are designed to utilize the same software architecture (with only low-level controls differing) and general sensor configuration, which are chosen for ease of fleet expansion.

The core competencies of our autonomous vehicles are :

- Mapping and localization in 3D environment with synthetic 2D LIDAR [3], [4]
- Dynamic replanning for online obstacle avoidance [5]
- Moving obstacles detection and tracking [6]
- Intuitive web-based booking system [7]

The functionality of the service was demonstrated in an uncontrolled environment open to real pedestrian and vehicular traffic. It is shown that while the car can operate at higher speeds on the road, the golf car has the flexibility of operating in pedestrian areas where cars are not allowed, thereby expanding the area coverage of the MoD service.

In this paper, we present our autonomous mobility scooter as the newest addition to our multi-class mobility on demand fleet of autonomous vehicles.

The main contributions of this paper are:

- 1) *Design and development of a new autonomous personal mobility scooter capable for mobility on demand:* The compact size of the scooter enables us to extend the service reach into areas that are inaccessible to a road car or a golf car. The scooter also has an advantage when operating in crowded indoor environment, as it is easier to manoeuvre the smaller vehicle within dense crowds.
- 2) *Adapting our mapping, localization, perception, and planning capabilities to the scooter platform:* The personal mobility scooter is developed with similar sensors and software packages to what has been implemented in our road car and golf cars [8], maximizing

<sup>1</sup>Hans Andersen, Scott Pendleton, and Marcelo H. Ang Jr. are with the National University of Singapore, Singapore {hans.andersen, scott.pendleton01}@u.nus.edu, mpeangh@nus.edu.sg

<sup>2</sup>You Hong Eng, Wei Kang Leong, Chen Zhang, and Hai Xun Kong are with the Singapore-MIT Alliance for Research of Technology, Singapore {youhong, weikang, zhangchen, haixun}@smart.mit.edu

<sup>3</sup>Daniela Rus is with the Massachusetts Institute of Technology, Cambridge, MA, USA rus@csail.mit.edu

code re-usability and demonstrating the flexibility of our software architecture.

- 3) *Extensive experiments and user surveys*: The scooter was showcased during MIT’s open house to raise public awareness on autonomous driving technologies, 99 trips were recorded, with 73 m of distance covered per trip, totalling 7.23 km travelled in autonomous mode. Survey results have shown that our scooter is perceived to be safe and comfortable.

This paper is organized as follows. In Section II, related work on autonomous personal mobility vehicles will be reviewed. The hardware and software components of the system will be discussed in Section III. The experiment results will be presented in Section IV, and the paper is concluded in Section V.

## II. RELATED WORKS

The development of autonomous personal mobility devices has been an active research area since the 1980’s, as demonstrated by various autonomous wheelchair prototypes produced with intention to assist the disabled [9]. Notable recent projects include the MIT Intelligent Wheelchair Project, a voice commanded wheelchair for indoor use [10]. MIT’s robotic wheelchair is equipped with laser and odometry information to perceive its surrounding environment. The robot then follows a human tour guide and learns metric and topological representations of the environment during the tour. The wheelchair can subsequently query the previously named locations with voice commands and moves autonomously to the desired location.

An extension of the assistive autonomous wheelchair technology is to include manipulation capabilities into the robot. A collaboration between the University of Pittsburgh and Carnegie Mellon University has combined robotic manipulation with mobility [11], such that their robot can assist the disabled to perform day-to-day tasks on top of its mobility functions.

Navigation in crowded real world environments with autonomous wheelchairs has also been an interesting research challenge. The Smart Wheelchair System developed at Lehigh University [12] focused on navigation in structured outdoor environments and urban pedestrian areas such as side walks and university campuses. Their approach employed a map-based localization approach. A map of the environment was acquired using a server vehicle, synthesized, and made accessible to the autonomous wheelchair. The map embedded not only location but also semantic information of the landmarks. Localization is performed with both 2D and 3D LIDARs for landmark segmentation and tracking, with sampling-based motion planning and control software integrated for autonomous navigation functionalities.

The focus of this research is to provide autonomous personal mobility which cooperates with other classes of vehicle to realize a multi-class MoD service rather than designing autonomous technology for assistance to the disabled via private vehicle ownership. We built on our previous works in developing an autonomous road car and golf cars for both

urban road and pedestrian environments. With the addition of the new autonomous personal mobility vehicle, even a single passenger vehicle can be incorporated into a MoD scheme, whereas this vehicle type would be excluded from MoD if it were manually driven (if there is a driver, then there would be no room for a passenger). This new personal mobility vehicle class is small enough to travel even within the insides of buildings and perform tight manoeuvres in dense crowds, though it is also capable of outdoor operation. We have discussed various different localization and perception approaches in our previous work [8], with different environmental factors, sensor packages and redundancies involved. With the personal mobility vehicle, our approach to achieving autonomous navigation continues to be self-contained rather than relying on external infrastructure, so that it can be deployed in different environments, such as indoors and urban areas, where GPS signal is not strong enough to achieve decimetre level localization accuracy.

## III. SYSTEM OVERVIEW

The base platform of our autonomous scooter is the S19 from Heartway Medical. It is chosen for its compact and foldable form factor, such that it is able to navigate through crowded areas and around tight corners easily. The stock rated maximum payload is 115 Kg. The system is retrofitted with necessary sensors, actuators, power systems and computing units, and other features to perform the autonomous functions safely and comfortably. The final specifications of the scooter after retrofit are summarized in Table 1.

TABLE I  
PERSONAL MOBILITY SCOOTER SPECIFICATION

Dimensions (L x W x H)	930 x 485 x 2100 mm
Empty Weight	56 Kg
Maximum Payload	85 Kg
Maximum Speed	8.0 Km/h
Maximum Safe Slope	6 Degrees
Range	20 Km

The conversion of the scooter was kept as non-destructive as possible (minor drilling), with additional custom parts designed for assembly to the scooter using existing mounting points. The system and methods described here can be applied not only to this specific model of personal mobility scooter that we have converted, but can also be implemented to similar front-steered scooters, with the exception of hardware specific low-level (speed and steering) controllers. Key elements of the retrofitted system are highlighted in Fig. 1.

### A. Power System

The overall electrical system is described in Fig. 2. The scooter comes with a 24V, 11.5 Ah internal lithium-polymer battery, used to power the main motor as well as the accompanying stock circuits. Two external lead-acid batteries rated at 12V and 22Ah each are connected in series, to form an auxiliary 24V power supply. The auxiliary power

## Self-Driving Mobility Scooter



Fig. 1. Hardware overview, highlighting primary retrofit additions to a personal mobility scooter in order to enable autonomous capability

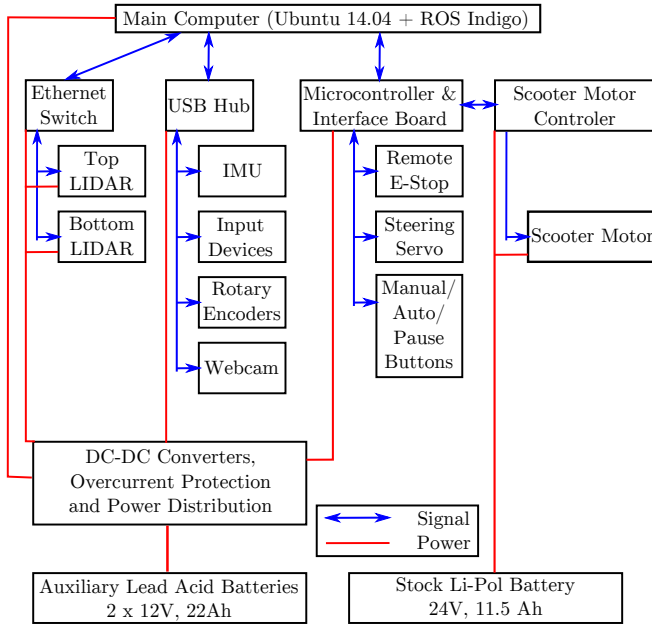

Fig. 2. Scooter electrical system connection diagram

supply is used to power the retrofit components, such that the added autonomous capabilities do not reduce the range and operating period of the scooter. DC-DC converters are used to distribute power according to the power requirement of each component. All components (computer and its peripherals, microcontroller, servo motor, sensors) are protected from over current using circuit breakers and fuses.

### B. Sensors

Two rotary encoders are installed to detect the rotation of the scooter’s driving wheels. The encoder assembly is shown in Fig. 3. The encoders are mounted on custom designed, 3D-printed brackets, which are securely fastened to the scooter’s frame, a piece of rubber sleeve covers the encoder shaft. A 3D-printed ring is installed on each of

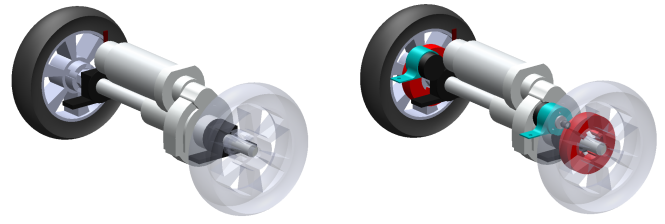

Fig. 3. CAD drawings of the scooter’s original motor and wheels assembly(left), and with rotary encoders mounted(right)

the wheel hubs, and its lateral section is in contact with the rubber sleeve on the encoder shaft. Contact friction rotates the encoder shaft as the driving wheel rotates. The elastic compliance of the encoder bracket ensures that the encoder shaft is in continuous contact with the ring, and the rubber sleeve ensures good contact friction and therefore minimizes slippage between the encoder shaft and the wheel hub. The encoders communicate to the computer through an interfacing printed circuit board. A MicroStrain 3DM-GX3-25 Inertial Measurement Unit (IMU) is rigidly mounted to the chassis above the center of the rear axle to provide attitude and heading of the vehicle (Fig. 1). The encoder and the IMU readings are fused to provide the vehicle’s 6 degrees-of-freedom odometry information.

Environmental sensing is achieved through 2 planar LIDARs. One SICK LMS 151 LIDAR is mounted at a tilted down angle, and the data returned is fused with odometry readings to achieve mapping and localization by the methods described in [3]. The SICK LMS151 scans at 50 Hz over 270 degrees with the range of up to 50 meters, and resolution of 0.5 degree. The LIDAR is mounted on a height of 1.9 meters in order to minimize obstructed visibility of the static environment by pedestrians’ bodies, thereby minimizing the potential resultant errors and uncertainties in scan-matching the sensor reading to a previously stored map. A SICK TiM551 LIDAR is mounted horizontally in the lower front part of the scooter for obstacle detection. It scans at 50 Hz for 270 degrees with the range of up to 10 meters, and resolution of 1 degree. A webcam is installed for recording purposes. All sensors are rigidly mounted to the chassis of the scooter (Fig. 1).

### C. Computing

A compact Gigabyte BRiX Pro computer is installed as the main computer for the scooter. It runs Ubuntu 14.04 with Indigo release Robot Operating System (ROS) [13] installed. The computer is fitted with an Intel Core i7-4770R processor running at 3.90 GHz, 16 GB RAM, and 250 GB SSD. The computer is also connected to the internet via 4G connection for accessing the booking system.

### D. Actuation

In order to operate autonomously, the controls of the scooter have to be accessible from computer commands. There are two primary control inputs to the scooter: steering

and speed. The speed input value to the controller can also take negative values indicating reverse motion.

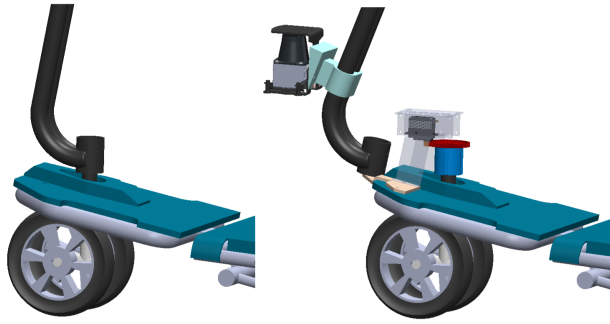

Fig. 4. CAD drawings of the scooter's original steering column assembly(left), and the repositioned steering column with steering servo mounted (right)

Steering actuation is achieved using a servo motor (Hitec HS-7945TH), with rated torque of 1.48 Nm, and rated speed of 0.14s/60 at no load. The motor is mounted to the scooter's steering column with a 7:1 spur gear as seen on Fig. 4.

Since the servo motor steers the steering column of the scooter directly in autonomous mode, a potential safety hazard could be posed if the passenger were to try to overtake the controls of the vehicle by manually steering the scooter. This potential hazard is overcome by removing the original steering handle and completely disabling mechanical steering. The original steering handle is remounted with a custom designed metal bracket to serve as a mount for the display, as well as to give the passenger a more familiar, secure, and comfortable feel when riding the scooter in autonomous mode as seen in Fig. 4. Manual controls of the scooter can only be achieved through software with a joystick controller installed. Additionally, geo-fencing is also used around the predefined routes to ensure that the vehicle does not travel too far away from the intended path, and stays stationary whenever it is localized outside of the intended operating area.

The longitudinal speed control of the scooter is achieved by an analog voltage input to the stock motor controller to imitate the output from a stock potentiometer circuit linked to a manual throttle control lever. The controller channel takes an input signal of 0-5 V, with 0V being maximum reverse speed, 2.5V being zero speed, and 5V being maximum forward speed. The stock throttle lever is removed altogether to prevent users from sending conflicting throttle messages to the scooter. Manual speed control of the vehicle is only possible through software and joystick control. A potentiometer is built into the scooter's controller board, which governs a maximum velocity restriction to the scooter, adding a manual customization of the ride comfort for the passenger. The maximum velocity of the scooter (when the potentiometer is set at its maximum velocity limit) is rated at 8.0 Km/h; however, for safety reasons, the maximum velocity of the scooter in autonomous mode is software limited to 3.6 Km/h.

### E. User Control and Safety Features

A STM32F4 microcontroller is used to publish control signals to the stock motor controller, to read the user control panel and to communicate with the main computer. A custom designed circuit board is used to interface the microcontroller, the buttons and the stock motor controller.

The passenger of the scooter has access to a user control panel with push buttons for basic mode selections. The buttons are illuminated to give the passenger a visual cue on the current operating mode. There are three available modes: manual, pause, and autonomous. In manual mode, only commands from the joystick will be executed; in pause mode, the scooter will stay stationary; while in autonomous mode, the scooter will execute the command velocity from the trajectory planner. Audio cues are given to the passenger and the environment through a speaker that signals whether the passenger has arrived at the final destination and therefore whether it is safe to alight from the scooter.

An emergency stop switch is placed strategically within the reach of the passenger, such that the passenger can stop the vehicle whenever an unexpected situation has happened. A wireless emergency relay has also been installed such that a safety officer during the public trial will always be able to change the operating mode of the scooter. Whenever emergency mode is triggered, the power to the scooter's motor is cut off, but not to the computer and its peripherals. A safety officer could then reset the user control panel and return the scooter to normal operating mode without much delay.

The batteries, power distribution box, the computer and its peripherals are safely tucked underneath the seat of the scooter, and the power buttons are placed such that they are protected from accidental contact with external objects. The steering servo motor, the microcontroller and the interface board are housed in a custom designed, laser-cut plastic case for added physical protection and better overall aesthetics.

### F. Software

The core subsystems of an autonomous vehicle can be broadly categorized into three categories: perception, planning, and actuation. Our implementation of the autonomous system architecture is depicted in Fig. 5

Perception refers to the ability of an autonomous system to extract relevant knowledge and understanding about its environment. This is achieved by taking measurements from the sensors, and processing the signals to extract relevant and meaningful information from those measurements.

Localization is performed based on the previously built map. Our localization system mainly consists of two parts, 3D perception to extract key feature points, and 2D localization to solve the localization problem on the horizontal plane. Synthetic LIDAR, a specific sensor model [3], serves as a bridge to connect the 3D world and the 2D virtual plane.

The 3D perception system accumulates the laser scans from a 2D tilted down LIDAR for 3D range data. A classification procedure is then applied to extract interest points from the accumulated data. The extracted laser points

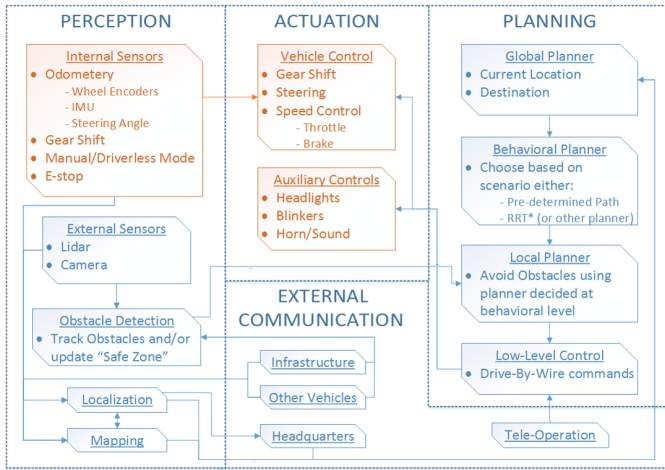

Fig. 5. System Architecture, [Source [2]]

are then projected onto a virtual horizontal plane, and a synthetic 2D LIDAR is constructed. The 2D localization fuses odometry information obtained from fusing encoder and IMU measurements, and measurements from the synthetic 2D LIDAR in a Monte Carlo Localization scheme, with referencing to a prior map of vertical features.

The mapping process starts with the acquisition of raw sensor data. The scooter is driven manually around the environment while recording the laser scan and odometry data of the trip. The raw sensor data are processed through a real-time 2D synthetic LIDAR conversion. The scan matching works together with loop closure detection to generate a constraint graph. Finally, the graph is used by the back-end to generate a globally consistent map while at the same time performing loop constraint rejection [4].

The localization and mapping algorithms were originally designed for use in an urban road environment that consist of concrete buildings and other man-made architectures, but the methodology adapts well in both outdoor pedestrian plazas as well as indoor environments.

To ensure safe navigation of the vehicle, a moving object recognition algorithm is implemented to detect and recognize moving obstacles in the environment [6]. The algorithm utilizes the spatial-temporal features of object clusters extracted from the bottom LIDAR scans, and performs object recognition via a Support Vector Machine (SVM) supervised learning method. This method is found to be accurate and reliable in the tested pedestrian environments.

Planning refers to the ability of an autonomous system to make purposeful decisions in order to achieve its goals. In this case, the primary goal is to transport passengers from designated pick-up stations to designated drop-off stations while avoiding collision with nearby obstacles.

We have designed a web-based booking system shown in Fig. 6 to accept mission requests. A mission ticket is created in the format of  $[Pick-up\ Station, Drop-off\ Station]$ , where *Pick-up Station* and *Drop-off Station* correspond to the passenger's pick-up location and passenger's destination respectively. The mission ticket is then sent to the central

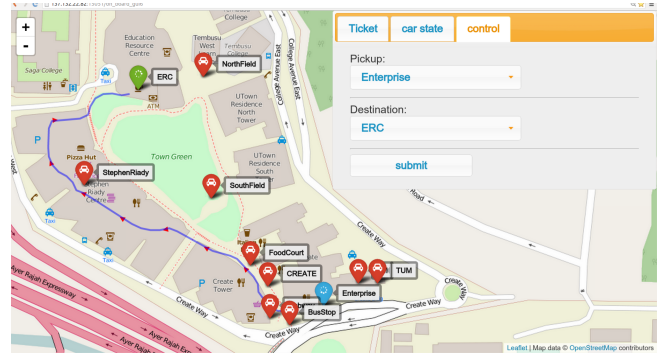

Fig. 6. Online booking system for National University of Singapore's University Town, with 11 stations shown. The blue line represents the path the passenger intends to travel which in this example is from "Enterprise" station to "ERC" station.

server which manages the database of all tickets in the mission pool and assigns missions to each vehicle in the fleet by a simple first-come first-serve basis.

The assigned vehicle's mission planner finds a route between the given pick-up and drop-off point. Predetermined paths are stored in a directed graph. The route searching module performs a Dijkstra search over a directed graph of reference path segments reflecting the road network connectivity.

A behaviour planner connects the mission planner and the motion planner, and is in charge of parsing the assigned mission into a set of actions and responsible for negotiation across the environment. The behaviour planner is implemented as a finite state machine [7]. One of its main purposes is to decide when to switch from reference path following to local replanning for obstacle avoidance, where the obstacle avoidance planner is triggered by measuring distance-to-collision.

A local planner based on the RRT\* Algorithm is implemented for local path replanning. The RRT\* algorithm guarantees asymptotic optimality of the path, in a sense that the solution trajectory can be incrementally optimized given enough planning time. Motion planning is conducted within the SE2 space and the system dynamics are simplified to the unicycle model, where Dubins paths are used to account for the kinematic constraints of the scooter.

Subsequently the finite state machine also decides when to transition from replanned path following to returning to original reference path following once the obstacle avoiding action is accomplished; i.e., when the sub-goals are reached, the vehicle should shift back to the normal travelling route following and start to approach the destination.

The dynamic virtual bumper (DVB), illustrated in Fig. 7 is utilized to generate an advisory speed for the vehicle's safe navigation in the presence of both the static and dynamic obstacles. The DVB is a tube shaped zone with its centerline as the scooter's local path, and its width  $w_t$  and height  $h_t$  defined as a quadratic functions dependent on the scooter's speed  $v_t$ .

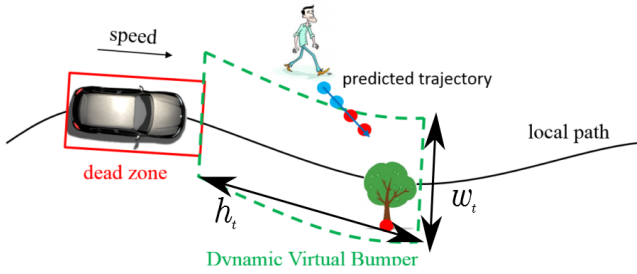

Fig. 7. An illustration of the dynamic virtual bumper [Source [8]]

$$w_t = w_0 + \alpha v_t^2$$

$$h_t = h_0 + \beta v_t^2$$

where  $w_0$  and  $h_0$  are the static distance buffers and  $\alpha$  and  $\beta$  are the coefficients that determine the growth rate of the dynamic virtual bumper as the velocity increases. LIDARs are used to detect obstacles in the vicinity. When an obstacle  $O_i$  is detected within the DVB, the vehicle will generate an advisory speed of a new desired DVB, whose boundary is marked by the position of the nearest obstacle. Since the desired DVB is smaller than the current DVB upon encountering a nearby obstacle, the newly calculated target velocity will be smaller than the current velocity, thus the vehicle will be advised to slow down. The DVB accounts for the presence of both static and moving obstacles, where the considered obstacle set  $O$  is defined by the union of static obstacle and moving obstacles sets,  $O = O_{static} \cup O_{moving}$ . While  $O_{static}$  can be directly obtained from sensor measurement,  $O_{moving}$  has to be obtained from prediction of moving object trajectories around the vehicle, and therefore the DVB may frequently adjust in size when dynamic obstacles are present.

Finally, the actuation competency, often referred to as motion control of an autonomous vehicle, refers to the ability of the system to execute the commands that have been generated by the higher level processes.

A speed generator developed by Reflexxes [14] is used to generate a speed profile for the advisory speed given by the dynamic virtual bumper. The currently implemented speed control is a simple PID (proportional, integral, derivative) controller with feed-forward compensation. The popular pure pursuit algorithm, discussed in detail in [15], is used for path tracking.

#### IV. EXPERIMENTAL RESULTS

The objectives of the experiment are

- To evaluate the autonomous driving capabilities of the scooter.
- To raise public awareness about autonomous driving technologies.

In order to evaluate its autonomous driving capabilities, the scooter was used to map the plaza area of National University of Singapore's University Town, as well as various

part of Massachusetts Institute of Technology's campus. The performance of the mapping and localization algorithm is evaluated based on the particle filter's standard deviation of the localization pose. The performance of planning and control methods is evaluated based on its capabilities to track the desired trajectory successfully and to avoid the static and dynamic obstacles that it encounters.

A public trial was conducted to raise public awareness about autonomous driving technologies. A survey was conducted to gain user feedback and background information. The public trial was conducted during MIT's open house on 23 April 2016 in one of MIT's parking lots (Massachusetts Ave and Vassar St). Rides on the scooter were offered to the public over the course of 5 hours. 99 trips were recorded, with 73 m of distance covered per trip, totaling 7.23 km traveled in autonomous mode. The survey results are then used to evaluate public perception on autonomous technologies.

MIT's infinite corridor presented unique challenges as compared to environments previously tested with the road car and golf cars. MIT's infinite corridor is a stretch of 251 m indoor hallway that connects some of the main buildings of MIT. Long corridors are particularly challenging due to lack of distinct vertical features and repetitive geometric shapes, and therefore the adaptive Monte Carlo localization system has to rely more on the vehicle's odometry system to localize well. Fig. 8 shows the standard deviation plots of the localization results relative to the vehicle's orientation.

In each grid, the color represents the relative average standard deviation value of the localization system as measured from the covariance matrix of the localization pose. Localization standard deviation remains well under 0.4 m with the exception in the sections of corridor where very little distinguishable vertical features can be extracted from the environment. Longitudinally, the largest deviation is obtained to be 0.66 m and laterally it is obtained to be 0.43 m. Overall, the average longitudinal standard deviation on the longitudinal is  $0.31 \pm 0.10$  m and, laterally it is  $0.17 \text{ m} \pm 0.07$ . It can be seen that the standard deviation value is larger longitudinally. This is also true when comparing two plots visually where the lateral plot remains in the colder spectrum of the colormap more than the longitudinal plot.

Selected results from the user surveyed gathered during the public trial are presented in Table 2. It was the first time for most of the visitors to take a ride on any form of autonomous vehicle, and the users surveyed did not have much prior background understanding on autonomous vehicles. The public response was encouraging, and gave very high rating for both the perceived safety and comfort of the scooter. Although the surveyed passengers perceived autonomous vehicles to have only a low to moderate level of safety before taking the ride in the scooter, this affirms our goal of changing the public perception on autonomous vehicles. An additional comments field was provided on the survey form in addition to the five questions shown in Table 2. In general, the public enjoyed the autonomous scooter ride, as evidenced from many indicating that they would

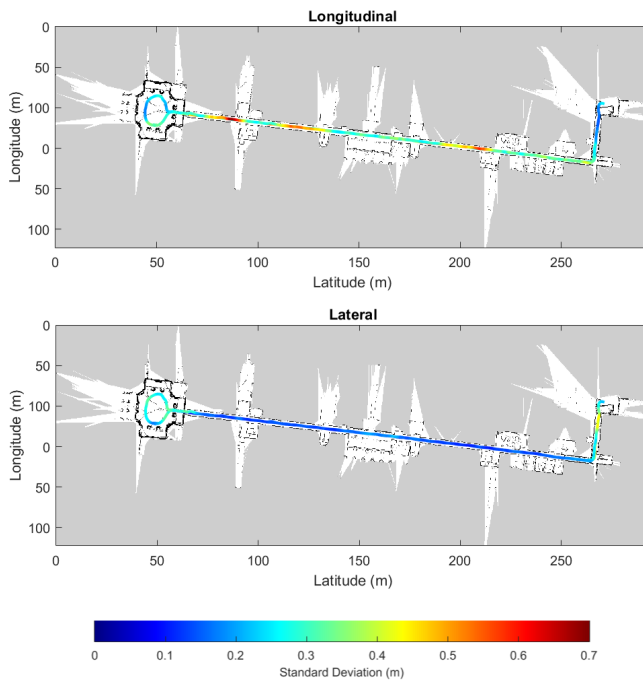

Fig. 8. Localization standard deviation results in MIT's infinite corridor (White pixels on the map represent empty space, while black pixels represent vertical features extracted with the synthetic 2D LIDAR)

want to ride the scooter again in the future and comments on surveys such as “fun” or “awesome,” etc. Suggestions were also made for the addition of a safety belt and arm rests to enhance safety and comfort, and these will be considered for future works. Some users reported that the speed of the scooter can be increased, as for safety reasons the scooter was limited to only 3.6 Km/h during the event. Since the scooter could only seat one passenger at a time, the demand was too high to give every visitor to the exhibit a ride. Nevertheless, many of those who did not ride enjoyed seeing their friends or family take rides and were interested to learn more about self-driving vehicles through the various videos and other displays shown at the exhibit. A video that showcases the capabilities of the scooter can be viewed at [https://youtu.be/\\_6otshNzqqo](https://youtu.be/_6otshNzqqo).

TABLE II  
PUBLIC TRIAL SURVEY RESULTS, WITH 99 USERS SURVEYED

How much do you know about autonomous vehicles?	2.2/5.0
How safe do you think autonomous vehicles are?	3.5/5.0
How would you rate your experience in terms of SAFETY?	4.6/5.0
How would you rate your experience in terms of COMFORT?	4.5/5.0
Would you ride on this autonomous scooter again?	96% Yes

## V. CONCLUSION

In this paper, we describe the system architecture of our personal mobility scooter. The scooter was designed with robustness, reliability, and safety in mind. The flexibility

of the system architecture and the software packages has been demonstrated by replicating the system architecture and adapting the software packages from our different classes of autonomous vehicles. The scooter was tested in both outdoor pedestrian environments, as well as crowded indoor environments with narrow corridors. The scooter has proven to be reliable over prolonged operations of several hours continuously. The positive public perception of the safety and comfort of the scooter as suggested from the survey is encouraging. As indicated from the popularity of the exhibit, our purpose of raising the public awareness and interest in autonomous vehicle technologies during the event were also achieved.

In the future we plan to use the scooter as a research platform to further improve the multi-class MoD service. We would also consider deploying and testing the in more challenging environments with narrow and crowded pathways over a prolonged period of time.

## ACKNOWLEDGMENT

This research was supported by the Future Urban Mobility project of the Singapore-MIT Alliance for Research and Technology (SMART) Center, with funding from Singapore's National Research Foundation (NRF).

## REFERENCES

- [1] Ministry of the Environment and Water Resources and Ministry of National Development, “Sustainable Singapore Blueprint 2015,” Tech. Rep., 2015. [Online]. Available: <http://www.mewr.gov.sg/ssb/files/ssb2015.pdf>
- [2] S. Pendleton, Z. J. Chong, B. Qin, W. Liu, T. Uthaicharoenpong, X. Shen, G. M. J. Fu, M. Scarnecchia, S.-W. Kim, M. H. Ang, and E. Frazzoli, “Multi-Class Driverless Vehicle Cooperation for Mobility-on-Demand,” in *Intelligent Transportation Systems World Congress (ITSWC)*, 2014.
- [3] Z. J. Chong, B. Qin, T. Bandyopadhyay, M. H. Ang, E. Frazzoli, and D. Rus, “Synthetic 2D LIDAR for precise vehicle localization in 3D urban environment,” in *IEEE International Conference on Robotics and Automation (ICRA)*, 2013, pp. 1554–1559.
- [4] —, “Mapping with synthetic 2D LIDAR in 3D urban environment,” *IEEE International Conference on Intelligent Robots and Systems*, vol. 3, no. 2, pp. 4715–4720, 2013.
- [5] W. Liu and M. H. Ang, “Incremental sampling-based algorithm for risk-aware planning under motion uncertainty,” *Proceedings - IEEE International Conference on Robotics and Automation*, pp. 2051–2058, 2014.
- [6] B. Qin, Z. J. Chong, S. H. Soh, T. Bandyopadhyay, M. H. Ang, E. Frazzoli, and D. Rus, “A spatial-temporal approach for moving object recognition with 2D LIDAR,” in *International Symposium on Experimental Robotics (ISER)*, 2014.
- [7] W. Liu, Z. Weng, Z. Chong, X. Shen, S. Pendleton, B. Qin, G. M. J. Fu, and M. H. Ang, “Autonomous vehicle planning system design under perception limitation in pedestrian environment,” in *2015 IEEE 7th International Conference on Cybernetics and Intelligent Systems (CIS) and IEEE Conference on Robotics, Automation and Mechatronics (RAM)*, 2015, pp. 159–166.
- [8] S. Pendleton, T. Uthaicharoenpong, Z. J. Chong, G. Ming, J. Fu, B. Qin, W. Liu, X. Shen, Z. Weng, C. Kamin, M. A. Ang, L. T. Kuwae, K. A. Marczuk, H. Andersen, M. Feng, G. Butron, Z. Z. Chong, M. H. Ang, E. Frazzoli, and D. Rus, “Autonomous Golf Cars for Public Trial of Mobility-on-Demand Service,” in *IEEE/RSJ International Conference on Intelligent Robots and Systems (IROS)*, 2015, pp. 1164–1171.
- [9] R. C. Simpson, “Smart wheelchairs: A literature review,” *Journal of Rehabilitation Research and Development*, vol. 42, no. 4, pp. 423–438, 2005.



- [10] S. Hemachandra, T. Kollar, N. Roy, and S. Teller, "Following and Interpreting Narrated Guided Tours," in *IEEE International Conference on Robotics and Automation (ICRA)*, 2011.
- [11] J. Xu, G. G. Grindle, B. Salatin, J. J. Vazquez, H. Wang, D. Ding, and R. A. Cooper, "Enhanced bimanual manipulation assistance with the Personal Mobility and Manipulation Appliance (PerMMA)," in *IEEE International Conference on Intelligent Robots and Systems (IROS)*, 2010.
- [12] C. Montella, T. Perkins, J. Spletzer, and M. Sands, "To the bookstore! autonomous wheelchair navigation in an urban environment," in *Field and Service Robotics*, 2014.
- [13] M. Quigley, K. Conley, B. Gerkey, J. FAust, T. Foote, J. Leibs, E. Berger, R. Wheeler, and A. Mg, "ROS: an open-source Robot Operating System," in *ICRA workshop on open source software*, vol. 3, 2009.
- [14] T. Kroger, "Opening the Door to New Sensor-Based Robot Applications The Reflexes Motion Libraries," in *IEEE International Conference on Robotics and Automation (ICRA)*, 2011.
- [15] S. F. Campbell, "Steering Control of an Autonomous Ground Vehicle with Application to the DARPA Urban Challenge," Master's thesis, Massachusetts Institute of Technology, 2005.